

# AC-DC POWER SUPPLIES

## UNIVERSAL INPUT, UP TO 65 WATTS

### INDUSTRIAL APPLICATIONS

#### UI65 SERIES

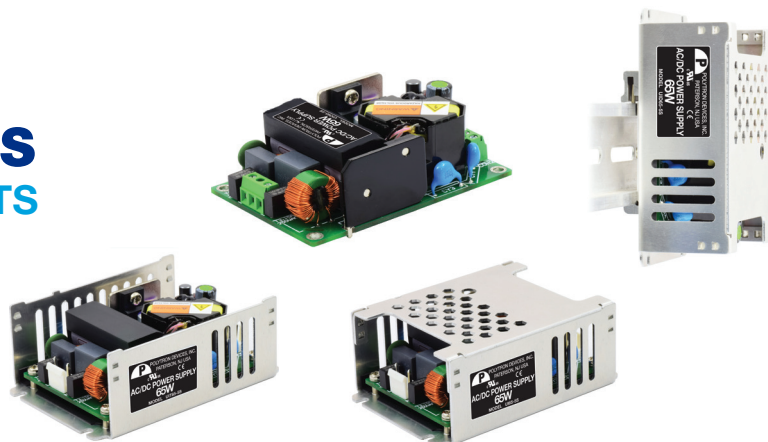

#### FEATURES

- Universal Input Range
- 0.11 Watt Low Standby Power Consumption
- Compact Package: 2.00" × 3.00"
- Wide Input Voltage Range 85 - 264 Vac, 47 - 63 Hz
- Built-in Class B EMI Filter
- Output Voltage Adjustable (Single Output Only)
- 3000 Vac Input to Output Reinforced Insulation
- Protection Type Class I and Class II
- Low Leakage Current Under 75µa
- Operating Altitude 5000M
- 3 Year Warranty
- Safety Meets: UL60950-1, EN60950-1 and IEC60950-1
- CE Marked: Design Meet IEC 61850-3
- Compliant to RoHS II & Reach

#### SELECTION GUIDE

All specifications are typical at 230Vac input, full load and 25°C, unless otherwise noted.

Input Range Vac	Output Voltage Vdc	Output Current at Natural Convention A	Max. Output Power W	Input Power at No Load W	Efficiency %	Model Number*	Maximum Capacitor Load µF
85 - 264	5	10	50	0.11	90	UI65-5SB	20,000
85 - 264	7.5	8.67	65	0.11	90	UI65-7.5SB	11,560
85 - 264	9	7.23	65	0.11	91	UI65-9SB	8,033
85 - 264	12	5.42	65	0.11	92.5	UI65-12SB	4,520
85 - 264	15	4.34	65	0.11	93.5	UI65-15SB	2,900
85 - 264	18	3.62	65	0.11	93.0	UI65-18SB	2,015
85 - 264	24	2.71	65	0.11	93.5	UI65-24SHB	1,130
85 - 264	24	2.71	65	0.11	92	UI65-24SB	1,130
85 - 264	28	2.33	65	0.11	93.5	UI65-28SHB	830
85 - 264	28	2.33	65	0.11	91.5	UI65-28SB	830
85 - 264	36	1.81	65	0.11	92.5	UI65-36SB	520
85 - 264	48	1.36	65	0.11	93	UI65-48SB	285
85 - 264	53	1.24	65	0.11	92.5	UI65-53SB	235

\* Open Type: UIO

Chassis Type: UIT

Din Rail: UID

Enclosed (Standard): UI

Screw Terminal: Suffix "T"

Class II Protection Type: Use Suffix "B"

Class I Protection Type: No Suffix

## UI65 SINGLE SERIES

Input Specifications			Output Specifications			
Voltage range	85 Min., 264 Max., Vac	AC input	Output power, Watt	65 Max.		
	120 Min., 370 Max., Vdc	DC input	Initial set voltage accuracy, %	-1 Min., 1 Max.	230Vac and Full Load	
Input frequency, Hz	47 Min., 63 Max.	AC input	Line regulation, %	-0.2 Min., 0.2 Max.	Low Line to High Line at Full Load	
Input current, A	1.6 Max.	100Vac and full load	Load regulation, %	-0.7 Min., 0.7 Max.	No Load to Full Load, 5Vout	
	0.9 Max.	240Vac and full load		-0.5 Min., 0.5 Max.	Others	
No load input power, Watts	0.11 Typ.	230Vac		-0.6 Min., 0.6 Max.	10% Load to 90% Load, 5Vout	
			-0.4 Min., 0.4 Max.	Others		
Leakage current, $\mu$ A	75 Max.	264Vac	Voltage adjustability, %	-20 Min., 10 Max.	Single Output, 53Vout	
				-10 Min., 10 Max.	Single Output, Others	
Start-up time, ms	1000 Max.		Minimum load, %	0 Typ.		
Rise time, ms	20 Typ.		Ripple and noise, mVp-p	Measured by 20MHz bandwidth		
				75 Typ.	With a 10 $\mu$ F/25V 1206 X7R MLCC, 5Vout, 7.5Vout, 9Vout, 12Vout, 15Vout	
				75 Typ.	With a 1 $\mu$ F/50V 1206 X7R MLCC, 24Vout, 28Vout, 36Vout	
Hold-up time, ms	16 Typ.	115Vac and full load	150 Typ.	With a 0.1 $\mu$ F/100V 1206 X7R MLCC, 48Vout, 53Vout		
			Temperature coefficient, %/°C	-0.02 Min., 0.02 Max.		
Input inrush current, A	60 Max.	230Vac	Transient response peak deviation, %	3Vout, Max.	Load step change from 50-75% at 2.5A/ $\mu$ s	
			Transient response recovery time, $\mu$ s	600, Typ.		
Input protection	T3.15A/250Vac	Internal fuse in line and neutral	Over voltage protection, %	125 Min., 140 Max.	% of Vout(nom); Latch mode	
			Over load protection, %	145 Typ.	% of Iout rated; Hiccup mode	
			Short circuit protection	Continuous, automatic recovery		

General Specifications					
Isolation voltage, Vac	1 minute (2MOPP isolation)	Input to Output	3000 Min.		
		Input (Output) to F.G.	2500 Min.		
Isolation resistance, G $\Omega$	500Vdc		0.1 Min.		
Switching frequency, kHz	230Vac	5Vout		60 Typ.	
		7.5Vout		80 Typ.	
		9Vout		70 Typ.	
		Others		120 Typ.	

Environmental Specifications			
Operating ambient temperature, °C	Natural Convection with derating	-40 Min.	85 Max.
Storage temperature range, °C		-40 Min.	85 Max.
Operating altitude, m			5000 Max.
Shock		IEC60068-2-27	
Vibration		IEC60068-2-6	
Relative humidity	Non-condensing	5% to 95% RH	

## UI65 SINGLE SERIES

Physical Specifications			EMC Specifications			
Design meet safety standard	UL60950-1, EN60950-1, IEC60950-1		Specifications	Conditions		Level
Weight, g	117 (4.13oz)	UIO	EMI <sup>(1)</sup>	EN55011, EN55022 and FCC Part 15	Conducted	Class B
	157 (5.54oz)	UIT		Radiated	Class B	
	172 (6.07oz)	UI	Harmonic currents	EN61000-3-2	Full load	Class A
	193 (6.81oz)	UID	Voltage flicker	EN61000-3-3		
			ESD	EN61000-4-2	Air ±15KV and Contact ±6KV	Perf. Criteria A
Dimensions	2.00" × 3.00" (50.8mm × 76.2mm)		Radiated immunity	EN61000-4-3	20V/m	Perf. Criteria A
			Fast transient	EN61000-4-4	±4KV	Perf. Criteria B
MTBF	1.494 × 10 <sup>6</sup> hrs , MIL-HDBK-217F, Full load		Surge	EN61000-4-5	DM ±2KV and CM ±4KV	Perf. Criteria A
			Conducted immunity	EN61000-4-6	20 Vr.m.s	Perf. Criteria A
			Power frequency magnetic field	EN61000-4-8	100 A/M	Perf. Criteria A
			Dip and interruptions	EN60600-4-11	230Vac 50Hz, 30%, 20mS	Perf. Criteria A
					230Vac 50Hz, 30%, 500mS	Perf. Criteria A
		230Vac 50Hz, 60%, 1000mS	Perf. Criteria A			
		230Vac 50Hz, >95%, 10mS	Perf. Criteria A			
		100Vac 50Hz, >95%, 5000mS	Perf. Criteria B			
		Damped Oscillatory Wave	EN61000-4-18	DM ±1kV and CM ± 2.5kV	Perf. Criteria A	

**Note:**

- External components may be required for Class I application. For further information, please contact Polytron Devices, Inc.

**CAUTION:** This power module is not internally fused. An input line fuse must always be used.

### Characteristic Curve

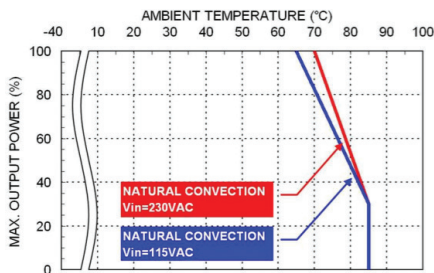

Derating Curve vs. Ambient Temperature

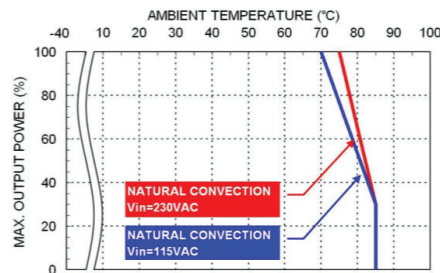

Derating Curve vs. Ambient Temperature

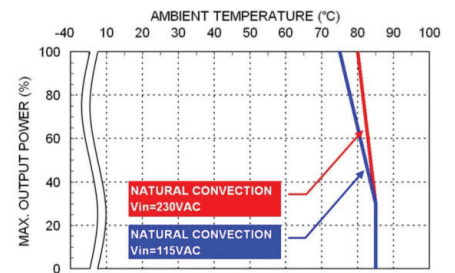

Derating Curve vs. Ambient Temperature

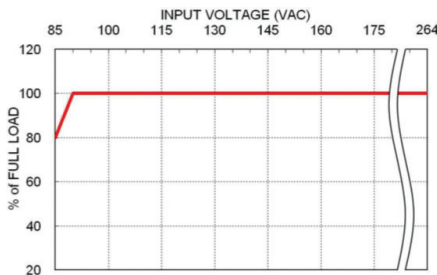

Derating Curve vs. Input Voltage

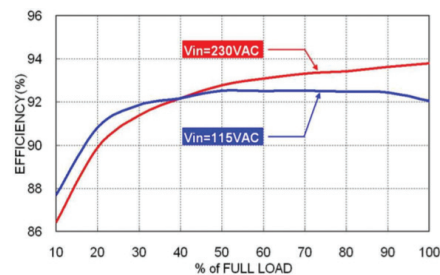

Efficiency vs. Output Load

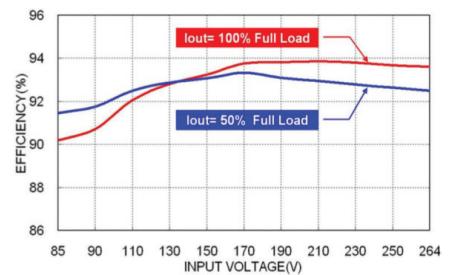

Efficiency vs. Input Voltage

## UI65 SINGLE SERIES

### Pin Connectors

#### CON1: INPUT CONNECTOR

PIN	
1	Line
3	Neutral

#### MATES WITH

JST Housing	VHR-3N
JST Crimp Terminals	SVH-21T-P1.1

#### CON2: OUTPUT CONNECTOR

PIN	
1, 2	-Vout
3, 4	+Vout

#### MATES WITH

JST Housing	VHR-4N
JST Crimp Terminals	SVH-21T-P1.1

#### Note:

1. Either one of four screws holes of Open/ Chassis Type can be considered as PE connection for Class I application.

### Mechanical Drawing

#### Open Type

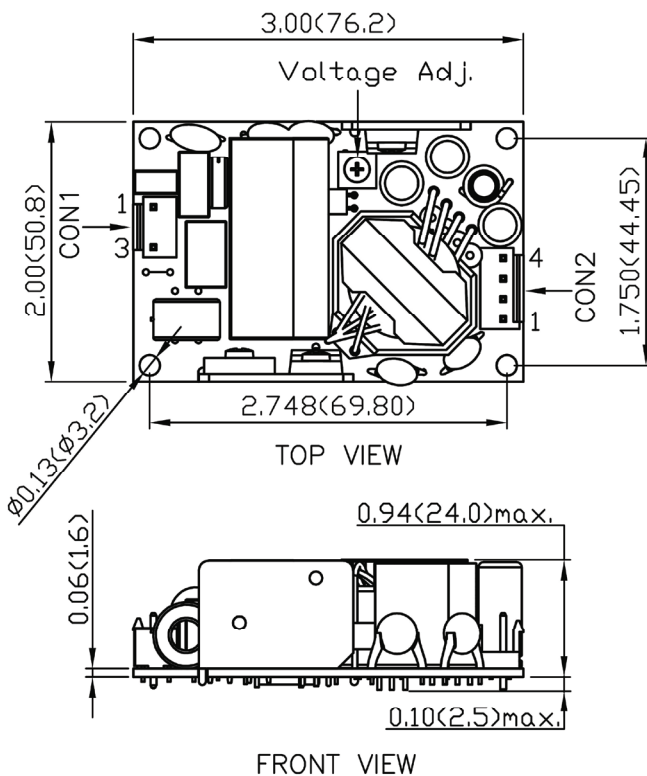

#### DIN Rail Type

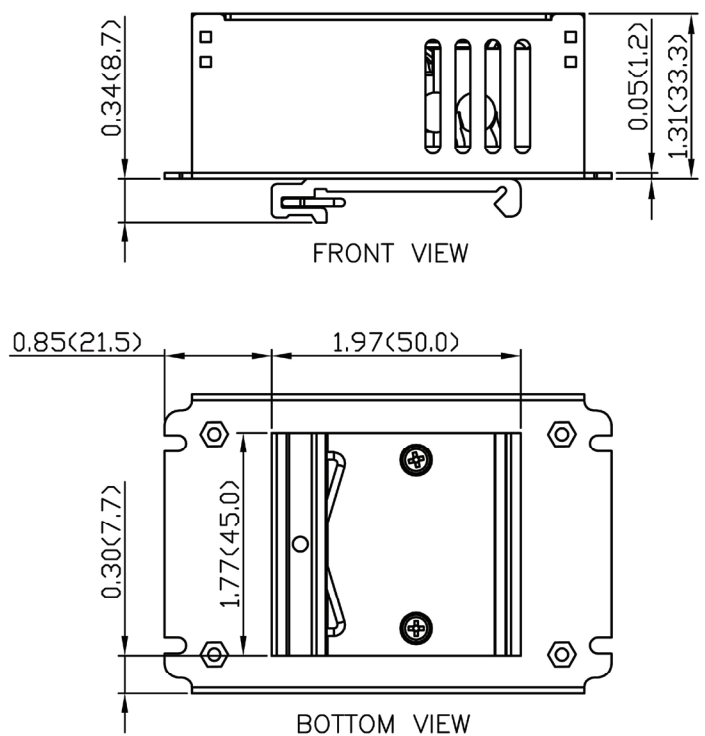

1. All dimensions in inch (mm)
2. Tolerance :x.xx±0.02 (x.x±0.5)  
x.xxx±0.01 (x.xx±0.25)
3. M3 × 0.5 screw locked torque MAX  
5Kgf.cm/0.49N.m

**UI65 SINGLE SERIES**

**Mechanical Drawing**

**Enclosed Type**

**U Chassis Type**

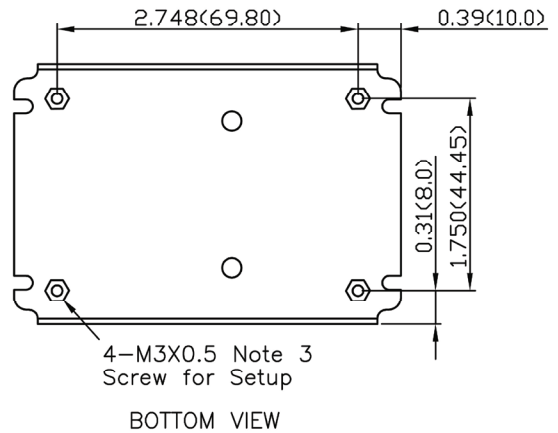
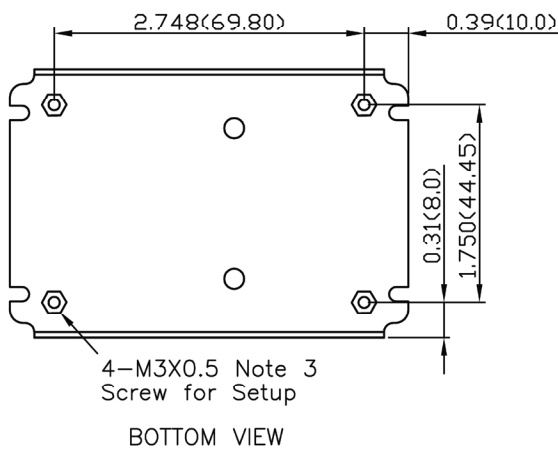
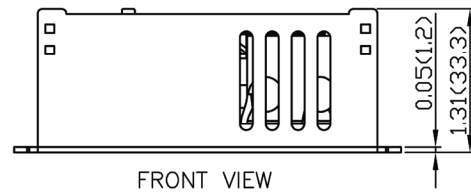
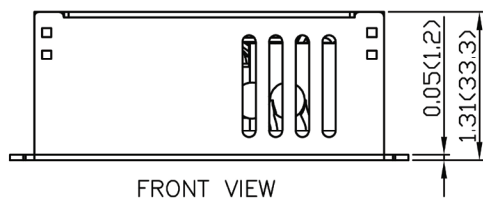
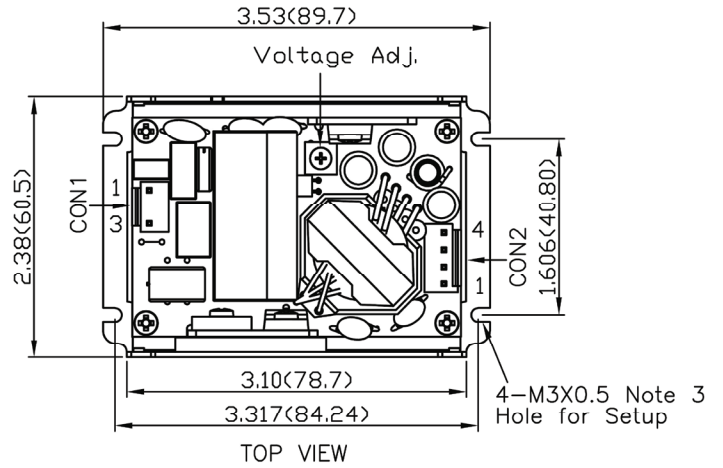
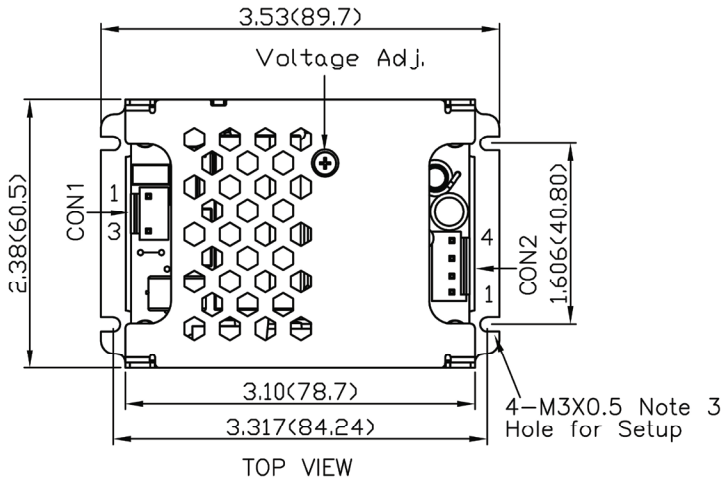

1. All dimensions in inch (mm)
2. Tolerance :x.xx±0.02 (x.x±0.5)  
x.xxx±0.01 (x.xx±0.25)
3. M3 × 0.5 screw locked torque MAX  
5Kgf.cm/0.49N.m